

Product Specification

Ord.-No.: **111 278 / E0683591**



Specification: Multi-clamp, V2A, Ø 4-6 mm/ Ø 4-6 mm carriage bolt M10

Performance: Multi-clamp according to DIN EN 62561-1 for the universal use as T-, cross-, parallel-clamp and joint-connector specially for reinforcements.

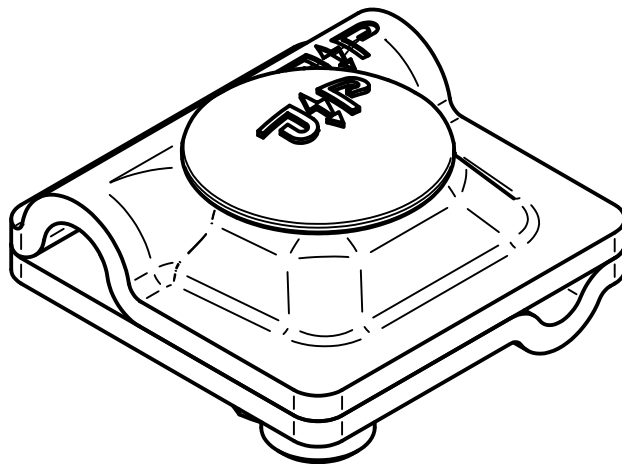
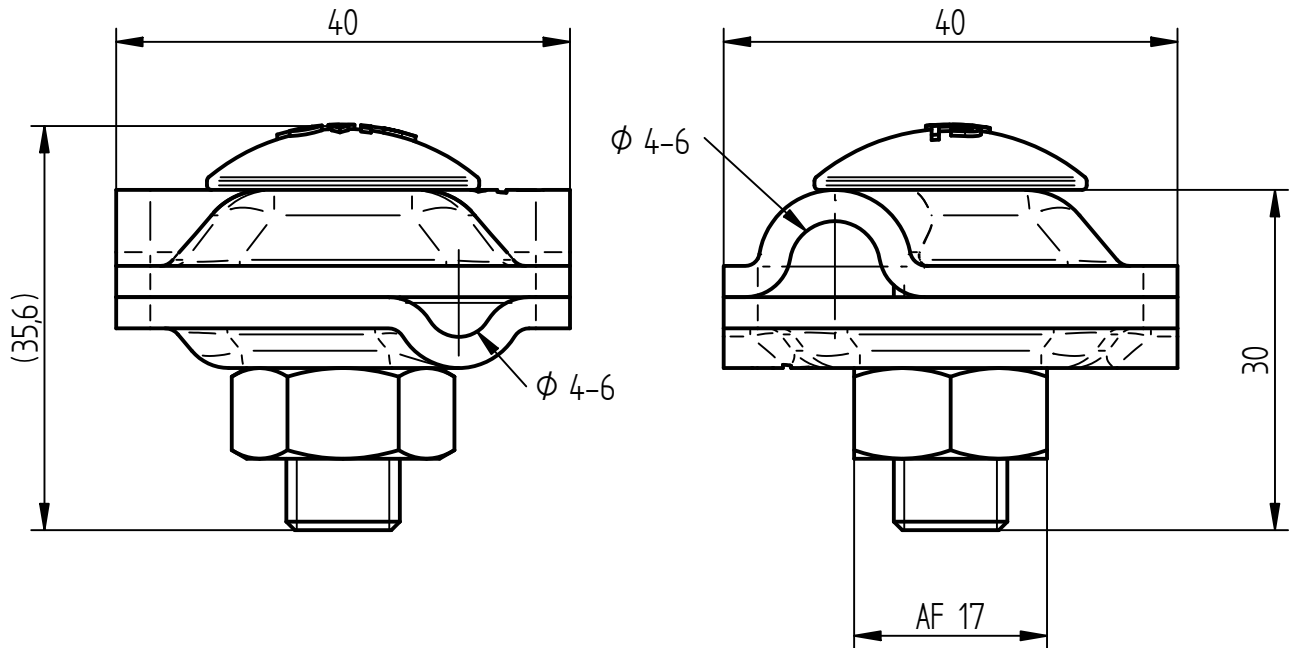

Material of clamp	Stainless steel V2A
Fit	Ø 4-6 / Ø 4-6 mm
Screw	Carriage bolt M10 with nut, V2A
Weight	106 g
Standard reference	DIN EN 62561-1
Packing unit	100 units