

Product Specification

Ord.-No.: 111 388 / E0683745



Specification: Terminal clamp, clamping range 19-36 mm V2A, with terminal lug, bore Ø 11 mm

Performance: Terminal clamp (heavy-duty type) according to DIN EN 62561-1 with terminal lug for the connection to steel constructions.

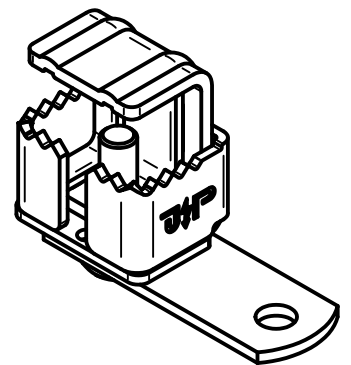
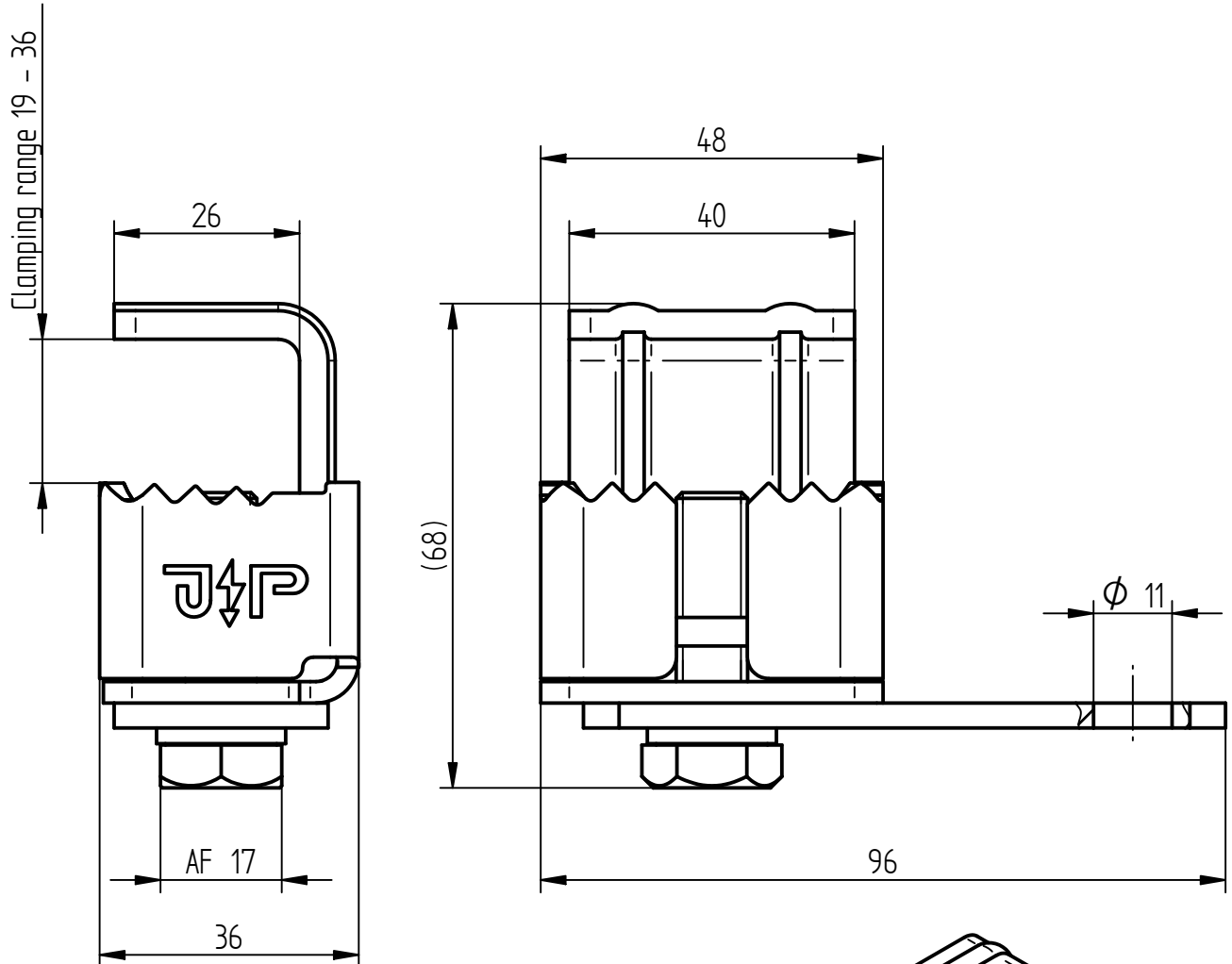

Suitable for the connection in explosive atmospheres in zones 2/22.

The clamp is secured against self-loosening by a spring washer according to DIN EN 62305-3 Supplement 2.

Material	Stainless steel V2A
Clamping range	19-36 mm
Terminal lug	Bore Ø 11 mm
Screw	Hexagon bolt M10 with spring lock washer, stainless steel V2A
Weight	328 g
Standard reference	DIN EN 62561-1
Packing unit	25 units