

Product Specification

Ord.-No.: 111 433 / E0680176



Specification: Multi-clamp, V2A, Ø 8-10 mm / Ø 16 mm

Performance: Multi-clamp according to DIN EN 62561-1 with intermediate plate for rod connection.

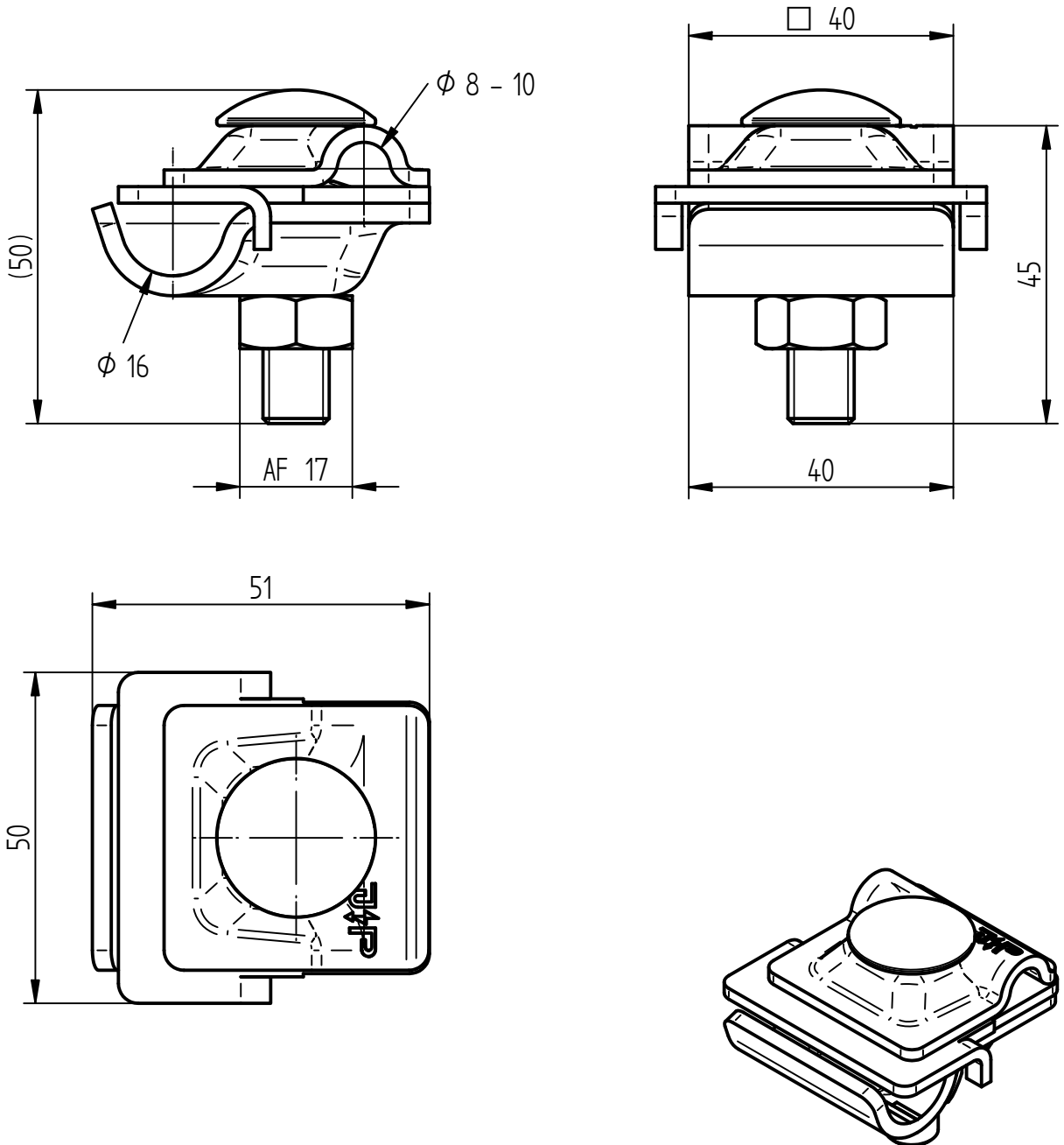

Material of clamp	Stainless steel V2A
Fit	Ø 8-10 mm/Ø 16 mm
Screw	Carriage bolt M10 with nut, stainless steel V2A
Weight	167 g
Standard reference	DIN EN 62561-1
Packing unit	50 units