

# Product Specification

**Ord.-No.:** **111 699 / E0683574**



**Specification:** ES-reinforcement clamp, St/tZn  
Ø 10 - 40 mm, Ø 10 mm / fl. 30 - 40 mm

**Performance:** ES-reinforcement clamp according to EN 62561-1 for the connection of round- and flat conductors on reinforced steel.

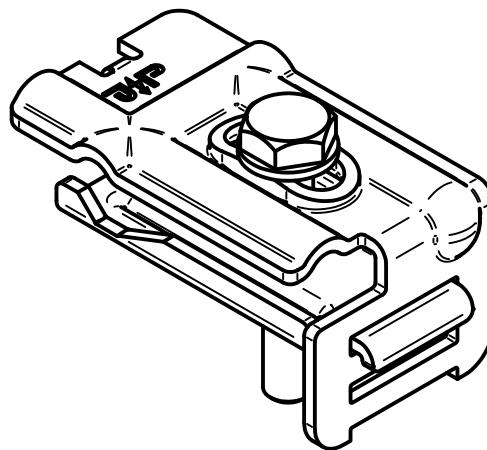
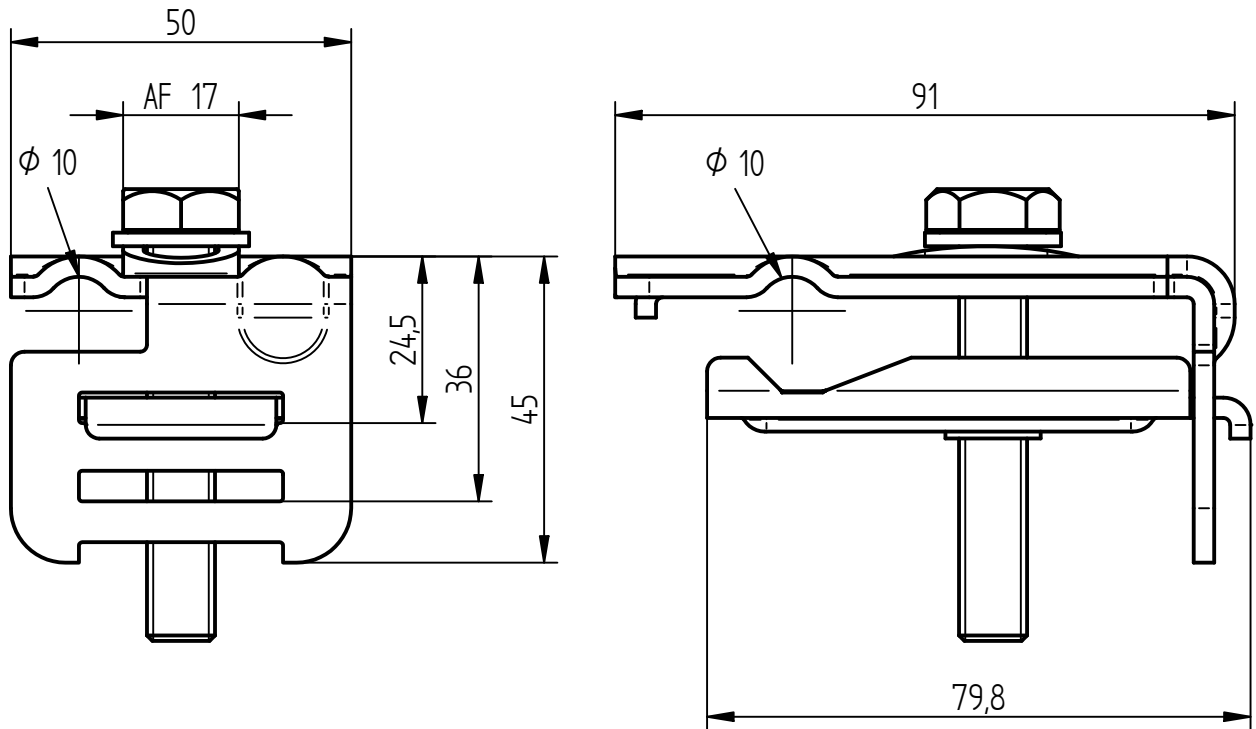

Material	St/tZn
Fit	round/flat
Reinforcement	Ø 10-40 mm
Earth conductor	Ø 10 mm/fl. 30-40 mm
Screw	Hexagon bolt M10, St/tZn
Washer	Stainless steel V2A
Weight	240 g
Standard reference	DIN EN 62561-1
Packing unit	25 units