

Product Specification

Ord.-No.: 111 797 / E0683566



Specification: Multi clamp fl./rd. for reinforcement St/
tZn, fl. 30 mm / Ø 5-25 mm

Performance: Multi clamp fl./rd. according to DIN EN 62561-1 for the connection of flat
conductors with the reinforcement in the concrete foundation.

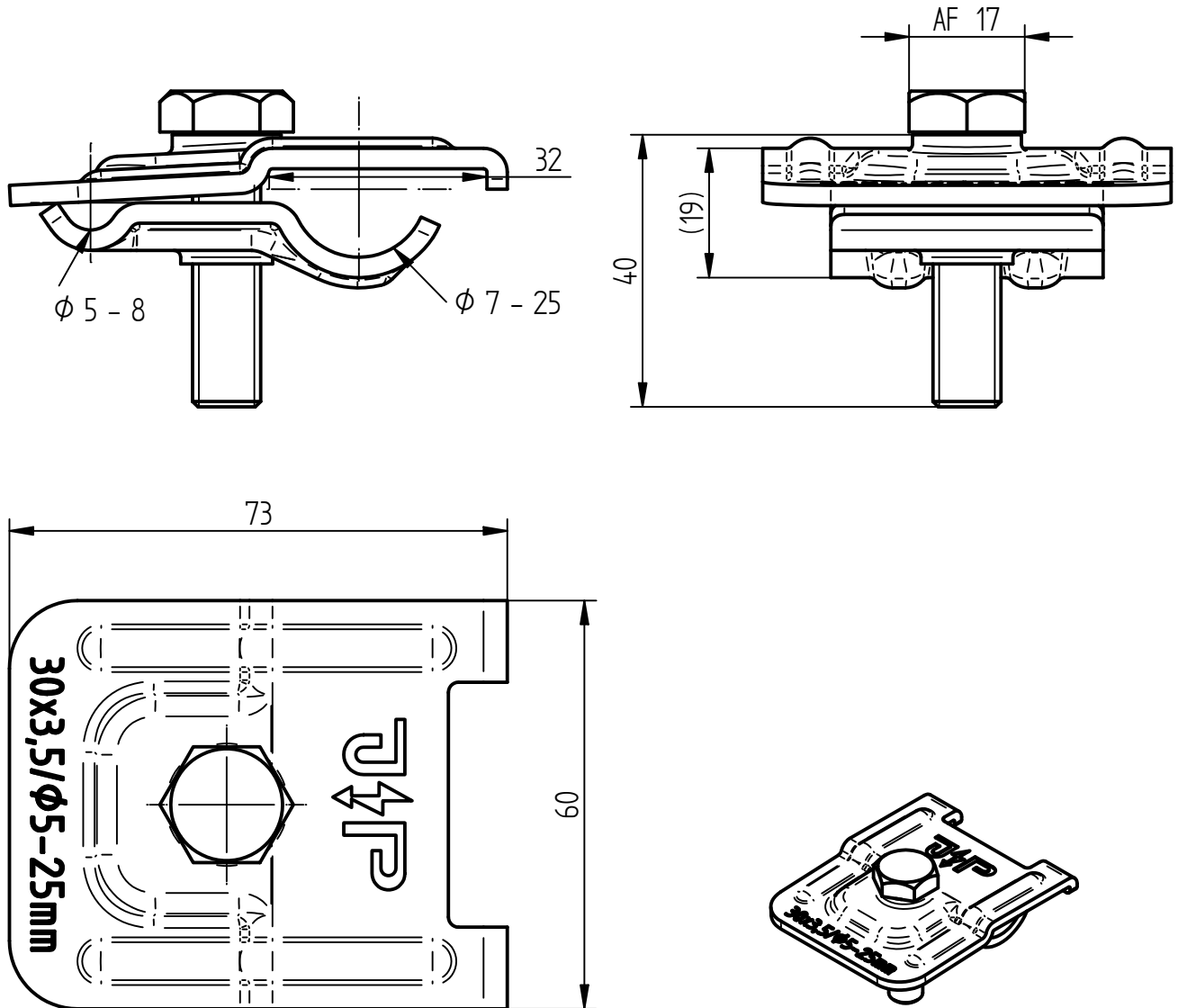

Material	St/tZn
Screw	Hexagon bolt M10, St/tZn
Fit of conductor	fl. 30 mm
Fit of reinforcement	Ø 5-25 mm
Weight	195 g
Standard reference	DIN EN 62561-1
Packing unit	25 units