

Product Specification

Ord.-No.: 2012 / E0683618



Specification: Vario-Disconnecting clamp, V2A
two-part, round/flat, Ø 8-10mm/fl. 30mm

Performance: Disconnecting clamp -Vario- according to DIN EN 62561-1 for test joints.

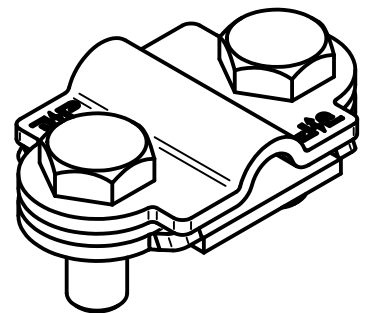
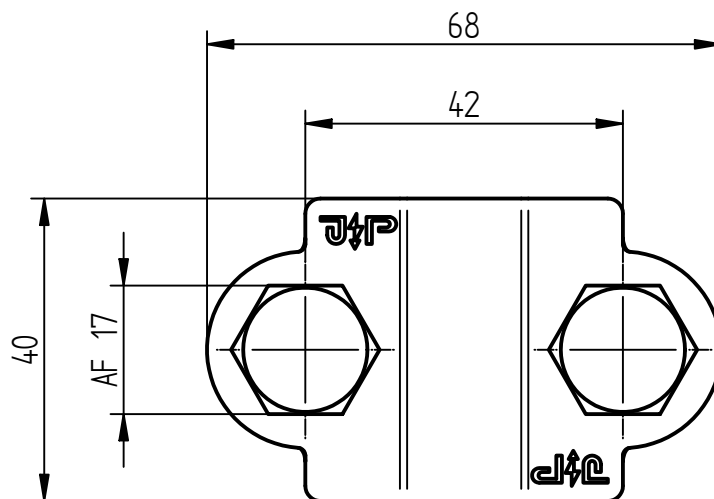
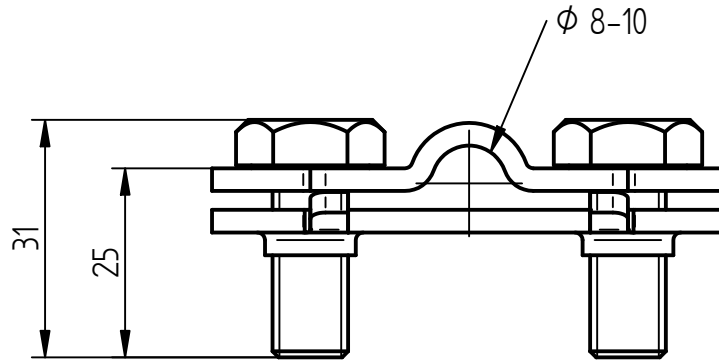

Material of clamp	Stainless steel V2A
Type of clamp	two-part, round/flat
Fit	Ø 8-10 mm/fl. 30 mm
Screw	[2x] Hexagon bolt M10, Stainless steel V2A
Weight	144 g
Standard reference	DIN EN 62561-1
Packing unit	50 units