

# Product Specification

**Ord.-No.:** 1031 / E0683577



**Specification:** Conductor fastener, V2A-PA6, Ø 8-10 mm with base grey, screw and dowel

**Performance:** Conductor fastener according to DIN EN 62561-4 for fixing round conductors to walls. Type with base, screw and dowel.

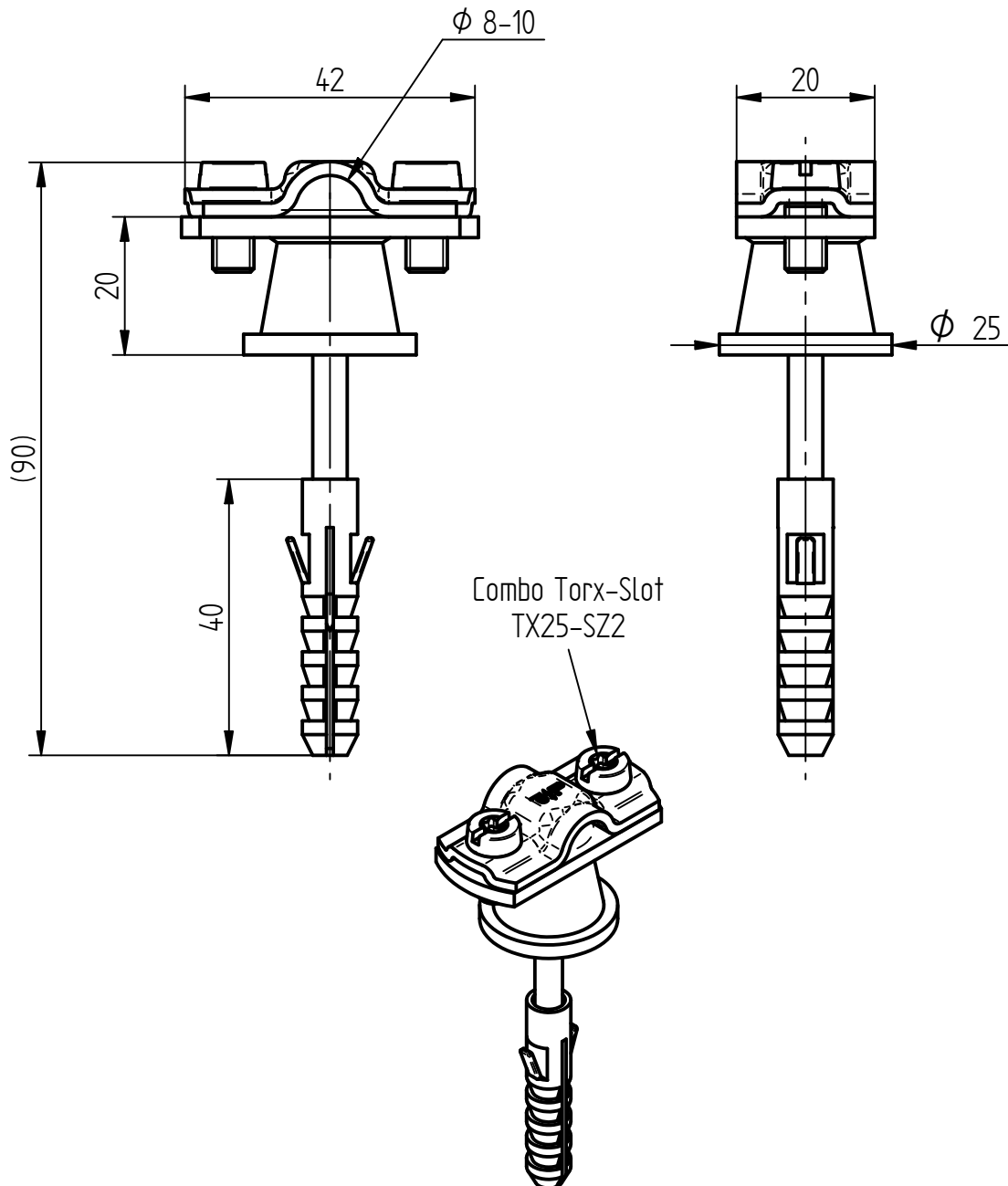

Material of base	PA 6 grey
Material of conductor fastener	Stainless steel V2A
Height of conductor leading	20 mm
Fit of conductor fastener	Ø 8-10 mm
Fit of dowel	Ø 8 mm
Weight	49,5 g
Standard reference	DIN EN 62561-4
Packing unit	100 units