

Product Specification

Ord.-No.: **1043 / E0680175**

Specification: Earth electrode inspection housing, cast with integrated test joint



Performance: Earth electrode inspection housing according to DIN EN 62561-5. Type with integrated test joint according to DIN EN 62561-1.

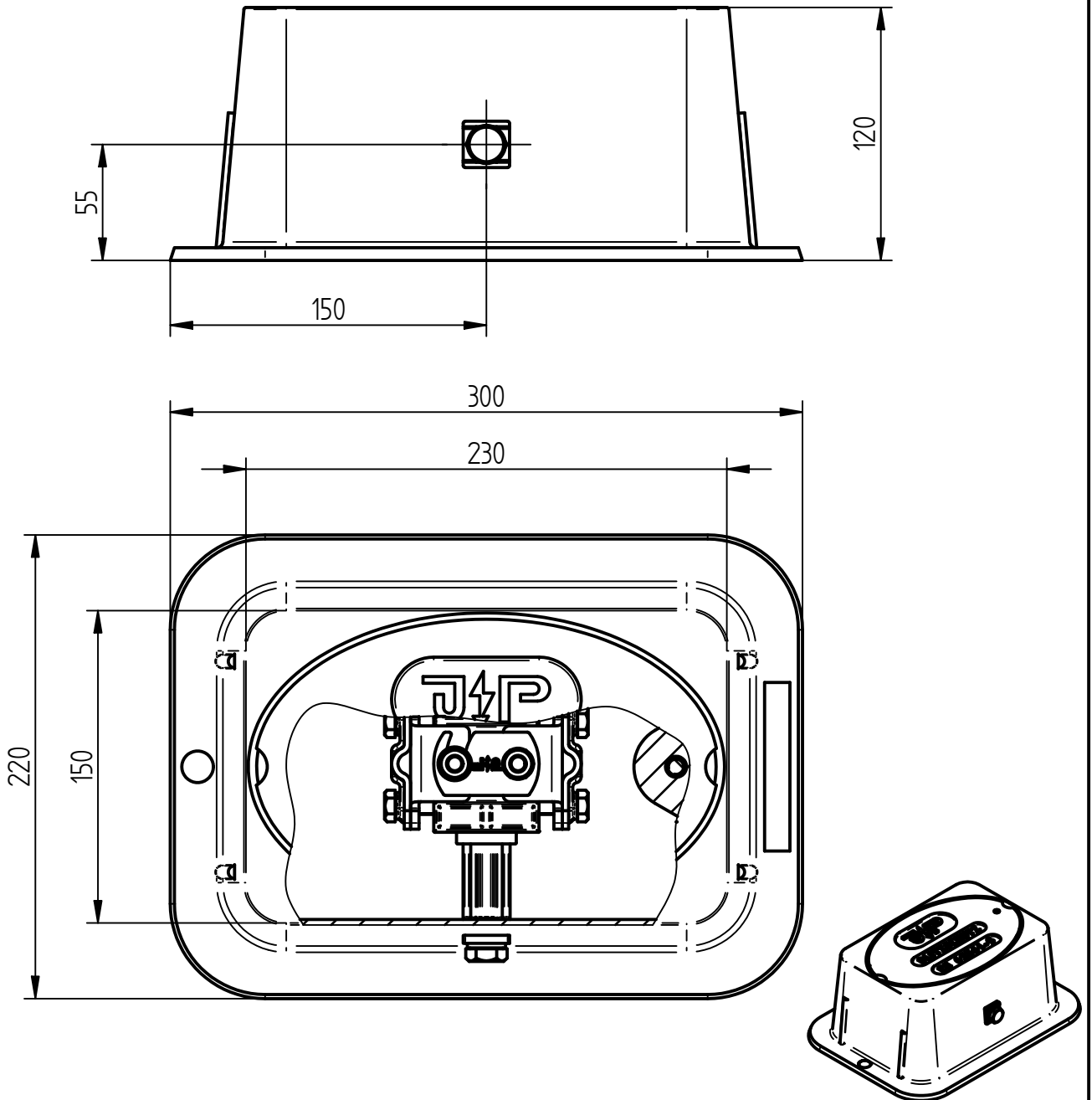

Material	grey cast iron
Colour	black, varnished
max. withstand load	40 kN (usage for heavy loading)
Mounting dimensions of box	230 x 150 x 120 mm
Dimensions of frame	300 x 220 mm
Fit of terminals	[2x] Ø 8-10 mm oder fl. 30 mm
Weight	7 kg
Standard reference	DIN EN 62561-1, DIN EN 62561-5
Packing unit	1 unit